

Vertikální vícestupňová odstředivá čerpadla IN-LINE
 Řada IN-V 2 / IN-V-S 2 / IN-V-S-V 2
 Výkonové charakteristiky

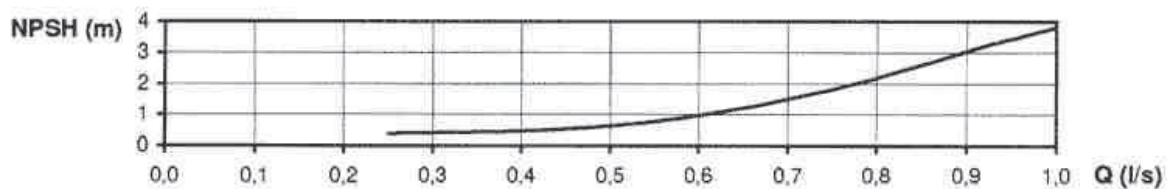

IN-V(S)

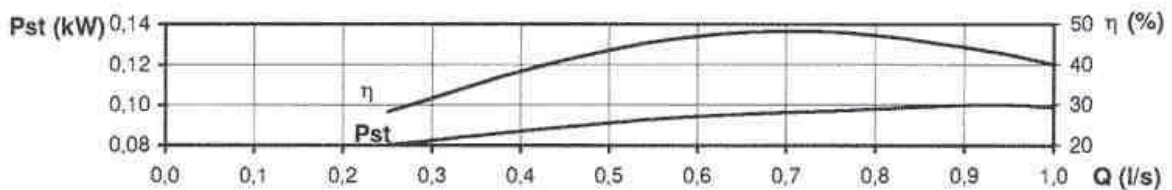
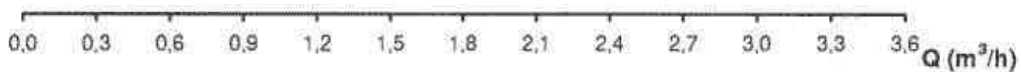
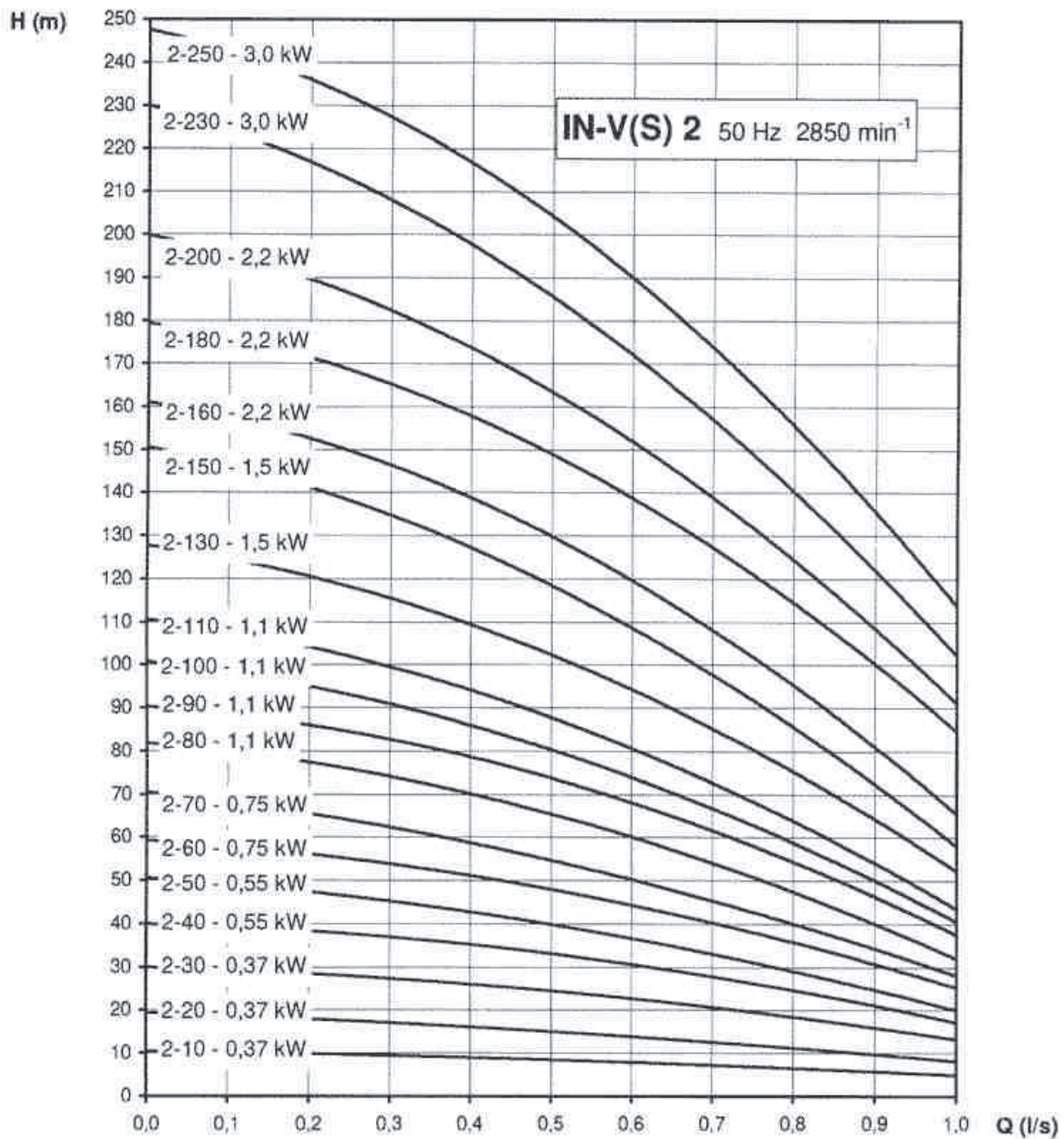
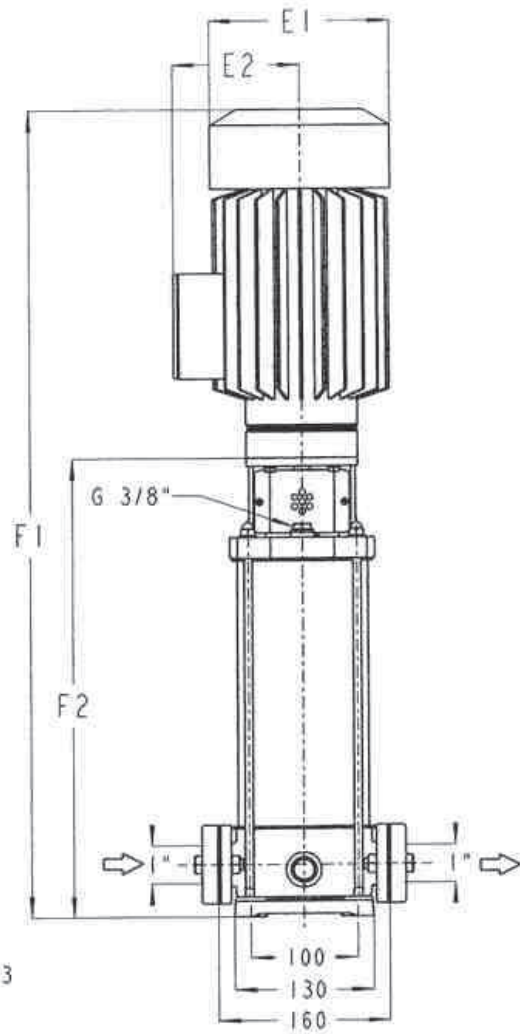
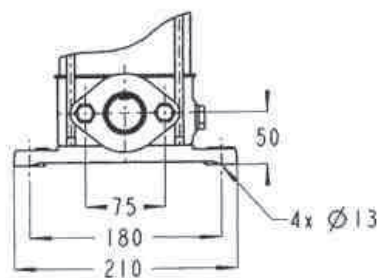

IN-V(S)-F

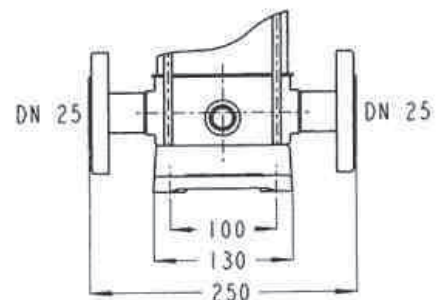
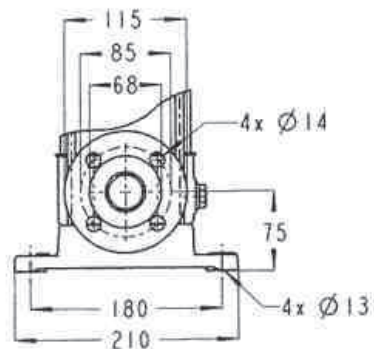

IN-V-S-V

